

LCD Touch Monitor

GM-GTC-1501F-B

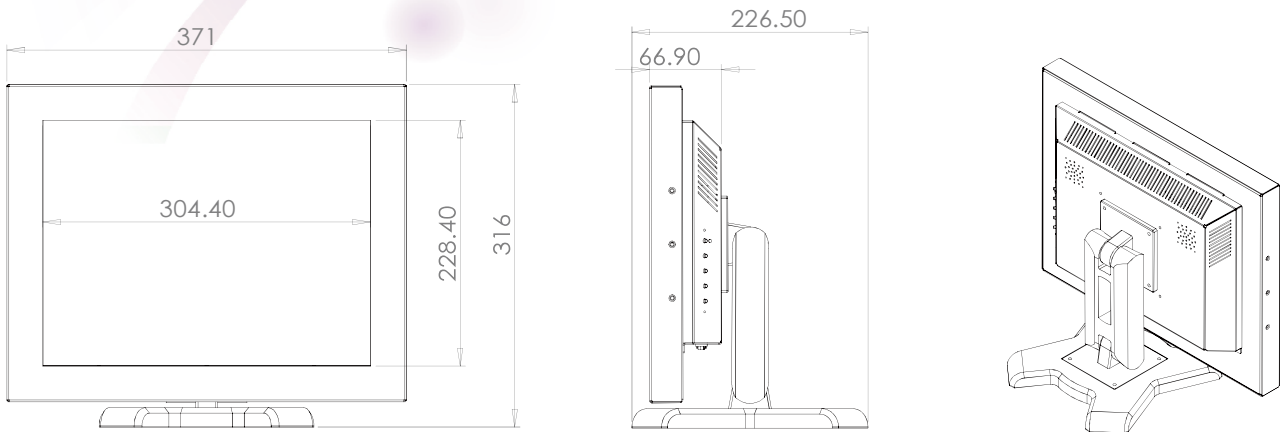

| Parameter | Specifications | Unit |
|-----------------------|--------------------------------------|-------------------|
| Display Size | 15 | Inch |
| Case Material | Matal | |
| Contrast Ratio | 350:1 | - |
| Brightness | 450 (Typ) | cd/m ² |
| Display Area | 304.1(H) x 228.1(W) | mm |
| Dimension | 316(H) x 371(W) x 226.5(D) | H/W/D |
| Video Mode | VGA SVGA XGA | - |
| Pixel | 0.294(H) x 0.294(W) | |
| Vertical Frequency | 56~75 | HZ |
| Colors | 16.2M | |
| Response Times | Tr=5, Td=20 | ms |
| Viewing Angle | 50,80,80 | Deg. |
| Backlight Life Time | 40,000 | hour |
| Video Input Signal | VGA DVI | |
| Operating Temperature | 0-50 | C |
| Input Voltage | DC-12 by Adapter | V |
| Power Consumption | 36 | W |
| Weight | 7 | kg |
| Touch Mode | IR or SAW or Resistive or Capacitive | Opention |
| Guaranty (Monitor) | 2 | year |

• The specification and feature are subject to change without prior notice.



坤巨資訊股份有限公司
Groovy Technology Corporation

台北總公司 Taipei Head Office

TEL: 886-2-26562589 FAX: 886-2-26578282

114 台北市內湖區基湖路35巷2弄9號3樓

3F., No.9, Alley 2, Lane 35, Jihu Rd., Neihu District,
Taipei City 114, Taiwan

深圳總公司 China Branch Office

TEL: 86-755-25327085 FAX: 86-755-83687759

深圳市福田區福虹路世貿廣場A座15樓1505

Room 1505, 15F, World Trade Piazza, FuHong Rd.,
Futian District, ShenZhen City, China