

坤巨資訊股份有限公司  
GROOVY TECHNOLOGY CORP.

SPECIFICATIONS OF TOUCH CONTROLLER

觸控面板控制器標準規範書

Date(日期): 2007/02/05

Customer(客戶):

Model(型式): ET-1232BSP

Mode(種類):

Customer Approval(客戶確認)

Customer Approval(客戶確認)

Approve(確認)	Checked(審閱)	Preparation(製表)

**GROOVY TECHNOLOGY CORP.**  
2F,NO.2,LANE 252,SEC.3,CHUNG GHING  
N.ROAD,TAIPEI,TAIWAN  
TEL : +886-2-25952775 FAX : +886-2-25949489  
EMAIL : groovy@seed.net.tw  
http : //www.gtouch.com.tw

坤巨資訊股份有限公司  
台北市重慶北路三段 252 巷 2 號 2 樓  
電話 : 02-25952775 傳真 : 02-25949489  
EMAIL : groovy@seed.net.tw  
網址 : http : //www.gtouch.com.tw

## CONTENT

1. Application and versions-----	2
2. Function -----	2
2.1 Summary -----	2
2.2 Block Diagram -----	2
2.3 Interface Specifications -----	3
2.3.1 Interface For HOST Side -----	3
2.3.2 Interface For Touch Panel Side -----	3
2.4 Signal Line And Timing Chart-----	4
2.4.1 Power On Reset-----	4
2.5 Touch-Panel Function-----	5
2.5.1 Coordinate Placement -----	5
2.5.2 Output Data-----	5
2.6 Plug and play (PnP) ID response -----	6
2.6.1 Forwarding method -----	6
2.6.2 PnP ID response operation -----	6
3. Electrical Characteristics -----	7
3.1 Absolute Maximum Rating -----	7
3.2 DC Electrical Characteristics -----	7
4. Mechanical Specification -----	8
4.1 External Shape Of Control Board -----	8
4.2 Height Of Component Mounting-----	9
4.3 Weight -----	9
4.4 Interface Connector-----	9
5. Packing Method -----	10
5.1 Electrostatic Prevention Air Bag-----	10
5.2 Master Carton-----	10

## 1. APPLICATION AND VERSIONS

4W-232 serial products is solution for touch panel application. The controller is designed for fully integrated pen-touch application. The 4W-232 support serial interface include PnP. It also provides 12 bit ADC resolution. It is good for pen-touch with low-power application.

## 2. FUNCTION

### 2.1. SUMMARY

The 4W-232 can work with standard mouse driver. It also works with provided driver. This board supports only 4-wire analog resistive film touch-panel. MCU mounted on this board does not have the calibration function. If a special device driver is installed, the application of the calibration and other function can be executed

### 2.2 BLOCK DIAGRAM

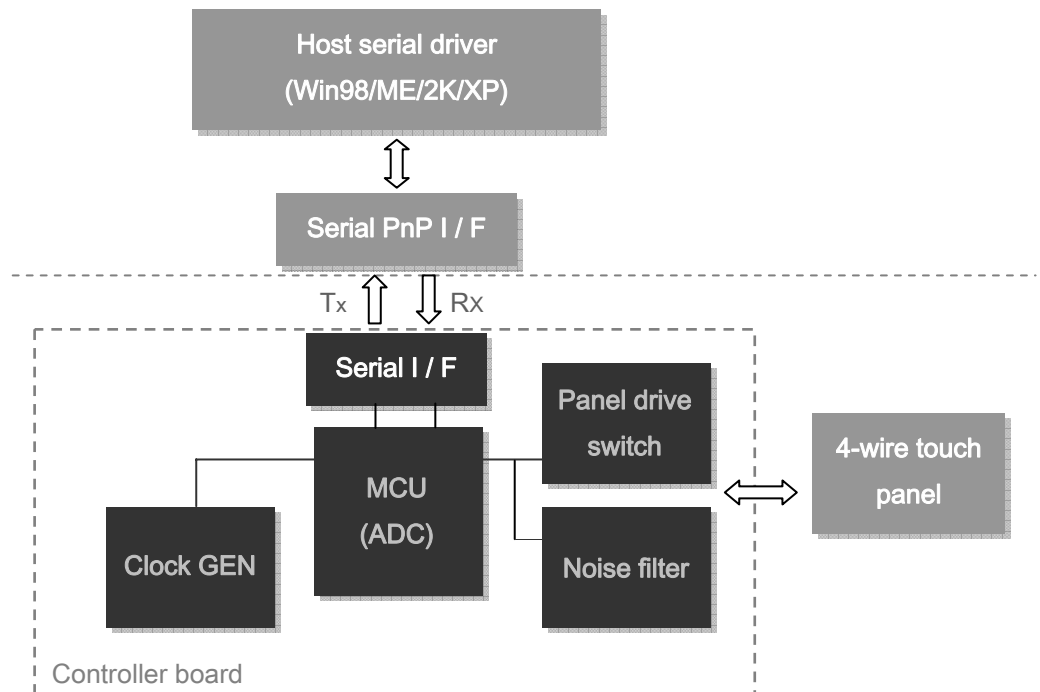

## 2.3 INTERFACE SPECIFICATIONS

### 2.3.1 Interface for HOST Side

Communication mode : Full duplex communication mode-serial interface.

Transmission speed : 9600 bps.

Data transmission mode : Asynchronous start-stop synchronization.

Signal level : Conforming to RS-232-C

Data format : Binary

Pin No.	Signal name	I/O	Specifications	Note
1	TXD	O	Data send signal	Approximately $\pm 12V$
2	RXD	I	Data receive signal	Approximately $\pm 12V$
3	DTR	I	Power and PnP request signal	Approximately $\pm 12V$
4	RTS	I	PnP request signal	Approximately $\pm 12V$
5	GND	-	Ground	0V

### 2.3.2 Interface for Touch Panel Side

Pin No.	Specifications / Standards
1	Up
2	Under
3	Right
4	Left

## 2.4 SIGNAL LINE AND TIMING CHART

### 2.4.1 Power on Reset

MCU is high level reset for at least 66ms while the oscillator is running in order to reset the entire MCU .

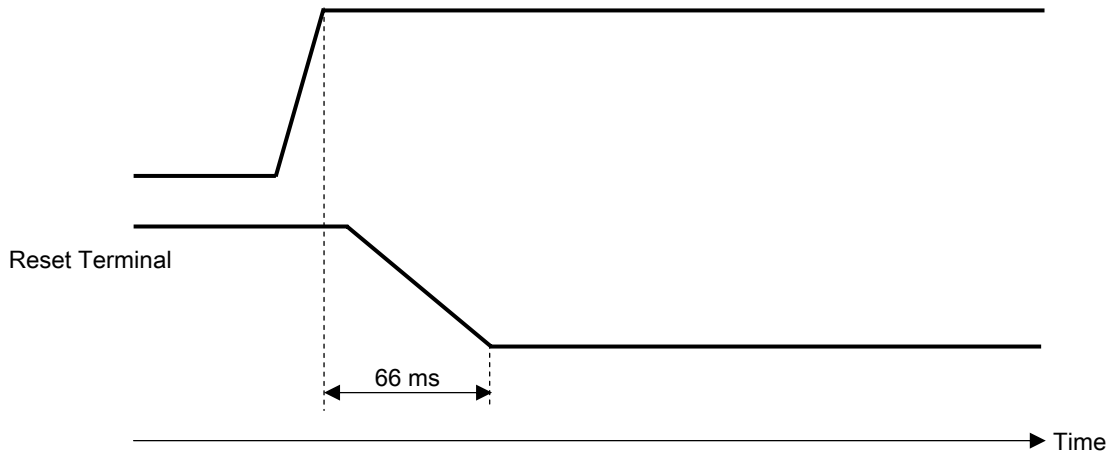

## 2.5 TOUCH-PANEL FUNCTION

### 2.5.1 Coordinate Placement

The coordinate for the initial status display the external shape of the panel. The origin is at one corner of the panel and the diagonal corner is the maximum value(X=4096 Y=4096). Accordingly, the minimum value of the input area is larger than 0 and the maximum value is less than 4096.

### 2.5.2 Output Data

The output data format is as follows

Byte	Definition	Explanation
Byte 0	Touch ON/OFF	Touch ON/OFF
Byte 2~ Byte 1	X Coordinates	The Data Numerical Value is 0~Max 4095
Byte 4 ~ Byte 3	Y Coordinates	The Data Numerical Value is 0~Max 4095

The above mentioned each coordinate value has the range of theoretical value of 12bit. However, this board guarantees the range of about 10bit when the penpoint rests, and guarantees the range 12bit when the penpoint moves (When you consider the loss in the panel electrode part).

A numeric range of the guarantee is not provided for here because the A/D translation accuracy depends on the accuracy of the supplied power greatly.

## 2.6 PLUG AND PLAY (PNP) ID RESPONSE

### 2.6.1 Forwarding Method

Transfer rate: 1200bps

Data transmission mode: Asynchronous start-stop synchronization

Signal level: Conforming to RS-232-C

### 2.6.2 PnP ID Response Operation

The operation when PnP ID is transmitted to the host is described as follows:

RTS means host's RTS signal

H means +5V(space)

L means -5V(mark).

It responds that the response of PnP ID : synchronizing with standing up of RTS=H(DTR signal is H) after 100ms.

When Power on is reset(DTR signal is H),this MCU is executed the PnP ID response. Connect DTR with RTS in the loop back on the PC side when you use the PnP function on windows PC.

### 3. ELECTRICAL CHARACTERISTICS

#### 3.1 ABSOLUTE MAXIMUM RATING (VSS=0V)

Parameter	Symbol	Rating	Unit
DC Supply Voltage	VDD	<+7.0	V
Input / Output Voltage	Vin	-0.5 ~ VDD+0.5	V
Operating Ambient Temperature	T(opr)	0 ~ 70	°C
Storage Temperature	T(stg)	-25 ~ 125	°C

#### 3.2 ELECTRICAL CHARACTERISTICS (VSS=0V,T(OPR)=0~70°C)

(VCC=5V±5%, GND=0V, TA=0~70°C ,Fosc=6MHz, Unless Otherwise Noted)

Parameter	Symbol	Min	Type	Max	Units	Condition
Operating Voltage	VDD	2.4	-	5.5	V	-
Operating Current	Iop	-	-	2	mA	OSC 4MHz @ 5.0V
Standby Current	Istb	-	-	1.0	mA	VDD=5.0V
OSC Frequency	Fosc	-	-	6	MHz	VDD=5.0v
Input High Level	Vih	4.0 / 2.5	-	-	V	VDD=5.0V/VDD=3.0V
Input Low Level	VIL	-	-	0.8/0.5	V	VDD=5.0V/VDD=3.0V
CPU Clock	Fcpu	0.03	-	6	MHz	Fcpu=Fosc@5V

Note: reset voltage only valid when serial function is used

## 4. MECHANICAL SPECIFICATION

### 4.1 EXTERNAL SHAPE OF CONTROL BOARD

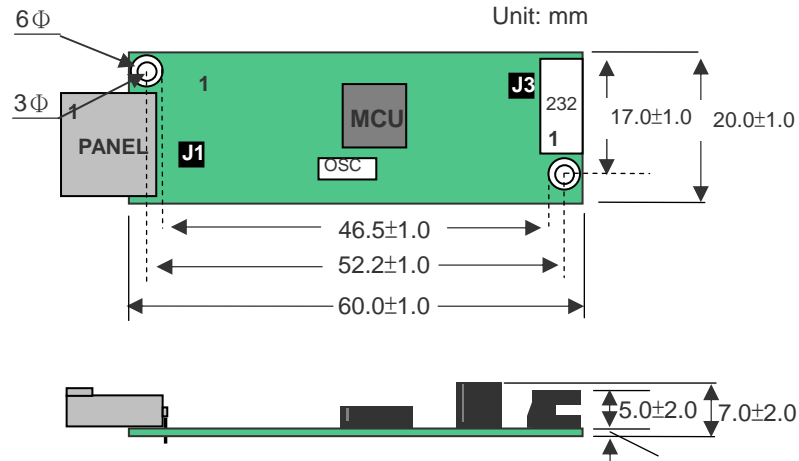

#### Interface for Host side (J3)

Pin No.	Specification
1	TD
2	RD
3	DTR
4	RTS
5	GND

#### Interface for touch panel side ( J1 )

Pin No.	Specifications / standards
1	Upper
2	Lower
3	Right
4	Left

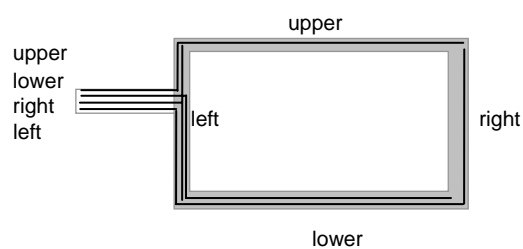

## 4.2 HEIGHT OF COMPONENT MOUNTING

8.6mm Maximum (Height of mounting from solder side)

## 4.3 WEIGHT

Around 7.1g

## 4.4 INTERFACE CONNECTOR

Serial Side : Wafer 2.00mm pitch connector

Touch Panel Side : 2.54mm Shrouded Header

## 5. PACKING METHOD

### 5.1 ELECTROSTATIC PREVENTION AIR BAG

Each control board will be arranged into electrostatic prevention air bag. (This is buffer material, so that is not shaking while transporting)

### 5.2 MASTER CARTON

Several partitions of the inner box will be arranged into a master carton. The required descriptions will print in the front of master carton:

**NOTE**

*The provider reserves the right to change product or specifications without notice. All trademark is belong to all origin company.*